

SQ-SI2X-360DA

SOLID-STATE WIDE RANGE MEMS INCLINOMETER
360° X 180° DUAL AXIS, SERIAL AND ANALOG OUTPUT

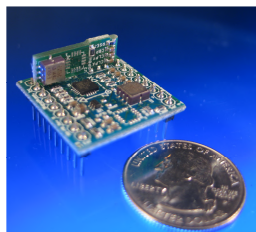

SQ-SI2X-360DA-HMP

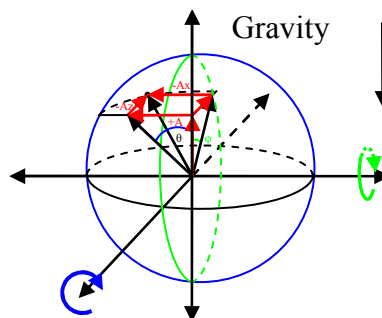

DESCRIPTION

The inclinometer module performs calibrated angle measurement with analog voltage and digital serial outputs.

FUNCTION

- Wide range 360° x 180° dual axis angle measurement

FEATURES

- ± 1° accuracy - differential
- 0.1° resolution - digital serial output
- 2° resolution - analog output
- Low temperature drift
- Factory calibrated angle output
- High reliability solid-state MEMS
- Digital filtering for stable measurement
- Direct PC interface cable

APPLICATIONS

- Platform and vehicle leveling
- Satellite dish and antenna alignment
- Machine control and monitoring
- Angle measurement and recording
- Computer input, head tracking, and mouse pointing

THEORY OF OPERATION

The inclinometer uses three factory calibrated accelerometers to measure and compute angles made between its axes and the gravity vector. The trigonometric conversions between acceleration and angle are made by an onboard processor. Digital filtering reduces the impact of spurious acceleration and vibration on the reported angle.

EXAMPLE OUTPUT

The graph below shows an example of the analog output from a device in single axis mode. The device is rotated 720° clockwise from a 0° starting position at a rate of 180°/sec. The output is linear with a piecewise overflow at 360°. The second axis output is similar, but each axis reaches a maximum at 180° and descends back to 0° rather than overflowing.

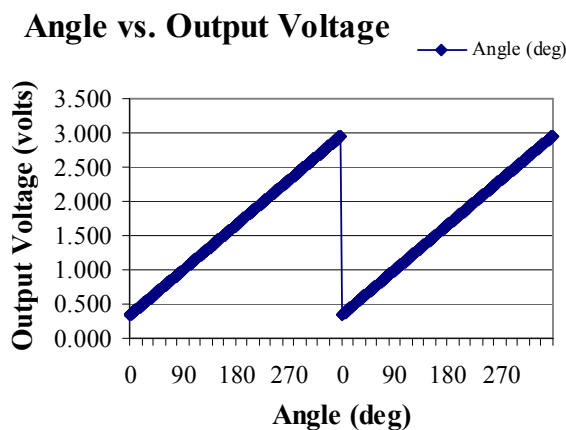

RANGE AND SCALE

PARAMETER	UNITS	VALUE
Scale Factor	V/deg	$0.0022 \times V_{cc}$
Offset (0° value)	V	$0.100 \times V_{cc}$
Max (359° value)	V	$0.895 \times V_{cc}$

$$Output(V) = Offset(V) + ScaleFactor(V/deg) \times Angle(deg)$$

$$Angle(deg) = \frac{Output(V) - Offset(V)}{ScaleFactor(V/deg)}$$

TABLE OF CONTENTS

Absolute Maximum Ratings.....	3
Electrical Characteristics.....	3
Performance Parameters.....	4
Output Characteristics.....	4
Pin Configuration.....	5
SQ-SI2X-360DA Series Package.....	6
Dimensions.....	6
Design, Layout, and Assembly Considerations.....	7
Serial Interface: HP and LP Versions.....	7
Example Output: HP and LP Versions.....	9
Orientation.....	10
Accessories.....	13
Limitations and Warnings.....	14
Testing.....	14
System Integration Testing.....	14

ABSOLUTE MAXIMUM RATINGS

PARAMETER	MIN	TYPICAL	MAX	NOTES
Voltage on $+V_{cc}$ - without regulator - NR option	-		4.2 V	With respect to GND
Voltage on $+V_{cc}$ - with regulator - R option	-		5.8 V	
Voltage on any input pin			5.8 V	With respect to GND
Peak-to-peak supply noise - without regulator -NR option			50 mV	
Peak-to-peak supply noise - with regulator - R option			200 mV	
Operating temperature	-40 °C		85 °C	
Shock survivability			500 g_n	Where 1 g_n is assumed to be = 9.81 m/s ²
Operating vibration			0.25 g_n	

Note: Exposure to conditions outside of the Absolute Maximum Ratings may damage the device. Prolonged exposure to conditions at the Absolute Maximum Ratings may result in degraded performance of the device over time.

ELECTRICAL CHARACTERISTICS

[Test conditions: 3.3v regulator, 25 °C unless otherwise specified]

PARAMETER	MIN	TYPICAL	MAX	NOTES
Supply voltage - without regulator - NR option	2.9 V		3.5 V	With respect to GND
Supply voltage - with 3.0 volt regulator - 3.0R option	3.2 V		5.8 V	12 V versions also available. Consult the factory.
Supply voltage - with 3.3 volt regulator - 3.3R option	3.5 V		5.8 V	
Supply current - HP option		5.4 mA		
Supply current - LP option		2.4 mA		
Supply current - ULP option	0.5 μ A	57 μ A	2.4 mA	Operating at 1 sample per second, no filtering, no oversampling
Output voltage*	0.3 V		$0.9 \times V_{cc}$	See note below regarding V_{cc}
Sensitivity*		$0.0022 \times V_{cc} / ^\circ$		
Full-scale output range*	$0.100 \times V_{cc}$		$0.895 \times V_{cc}$	
Analog output current			20 μ A	
Input voltage High	2.0 V			
Input voltage Low			0.8 V	
Output voltage High	$0.895 \times V_{cc}$		V_{cc}	
Output voltage Low	0 V		$0.100 \times V_{cc}$	

***Note:** For the NR model (without onboard regulator), V_{cc} is the voltage supplied to the device. For the 3.0R and 3.3R models (3.0 V or 3.3 V onboard regulators), V_{cc} is 3.0 V or 3.3 V respectively. If your application requires using a 12 V supply, consult the factory for 12 V models.

PERFORMANCE PARAMETERS

[Test conditions: 3.3v regulator, 25 ° C unless otherwise specified]

PARAMETER	SPECIFICATION		NOTES		
Angle accuracy (differential) - HP option	± 1 °		From any angle to any other angle within range		
Angle accuracy (differential) - LP option	± 2 °				
Angle accuracy (differential) - ULP option	± 2 °				
Angle resolution	2 ° (analog), 0.1 ° (digital)				
Alignment accuracy	± 2°				
Angle range - Tilt Mode	360 ° x 180 ° (X tilt, Y tilt)		Dual axis tilt ranges		
Angle range - Gimbaled Mode	360 ° x 90 ° (Y rotation, Y tilt)		Y rotation valid while Y tilt is within ± 45 ° of horizontal.*		
Typical angular drift due to temperature. Values represent 1 sigma confidence in tilt mode. - IND option			Angle range		
			± 10 ° from any axis	± 45 ° from any axis (max error)	
	Temperature range	15 C to +35 C	± 0.06 °	± 0.1 °	
		0 C to +70 C	± 0.3 °	± 0.6 °	
-40 C to +85 C		± 0.4 °	± 0.8 °		
Typical angular drift due to temperature. Values represent 1 sigma confidence in tilt mode. - LC option			Angle range		
			± 10 ° from any axis	± 45 ° from any axis (max error)	
	Temperature range	15 C to +35 C	± 0.3 °	± 0.6 °	
		0 C to +70 C	± 1.3 °	± 2.6 °	
-40 C to +85 C		± 1.9 °	± 4.8 °		

*Note: Angle ranges measured with respect to deviations from inertial X,Y, Z reference frame..

OUTPUT CHARACTERISTICS

PARAMETER – HP AND LP VERSIONS	TYPICAL	NOTES
Update rate - HP option	40 Hz	Analog update rate and Digital serial packet rate
Update rate - LP option	5 Hz	
Warm up time from power on - S option	1.0 s	Angle jitter and vibration are digitally filtered
Measurement settling time - S option	0.5 s	
Warm up time from power on - F option	0.2 s	
Measurement settling time - F option	0.1 s	
Analog output resolution	8 bit	9 bit actual resolution after PWM reconstruction filter.
PWM modulation frequency	5 kHz to 20 kHz	
PWM reconstruction filter bandwidth	10 Hz	Single pole RC.
Output impedance	10 kΩ	

PARAMETER – ULP VERSION	TYPICAL	NOTES
Update rate - ULP option	On demand up to 20 Hz	Serial output only. Analog output disabled.

PIN CONFIGURATION

PIN	SIGNAL NAME	USAGE
1	Ground	
2	UART Transmit	Digital Output – UART transmit line. Push-pull (not open collector). If not used, solder to open circuit for mechanical stability. Do not connect to GND or current drain will increase.
3	UART Receive	Digital Input – UART receive line. If not used, solder to V+ .
4	Baud Select	Digital Input – HP and LP version only. High selects high baud rate, Low selects low baud rate. If not used, solder to V+ .
5	+V _{cc} Supply	
6	X Tilt / Y Rotation Output	Analog Output – If not used, solder to open circuit for mechanical stability. Do not connect to GND or current drain will increase.
7	Y Tilt Output	Analog Output – If not used, solder to open circuit for mechanical stability. Do not connect to GND or current drain will increase.
8	Tilt Mode / Gimbaled Mode Select	Digital Input – High (or open) selects Tilt Mode, Low selects Gimbaled Mode. If not used, solder to open circuit for mechanical stability.
9	Noise Estimator	Solder to open circuit for mechanical stability. Do not connect to GND
10	NC	Solder to open circuit for mechanical stability. Do not connect to GND.
11	Self Test	Solder to open circuit for mechanical stability. Do not connect to GND
12	Resolution Select	Solder to open circuit for mechanical stability. Do not connect to GND
13	Flip X-Y	Solder to open circuit for mechanical stability. Do not connect to GND
14	NC	Solder to open circuit for mechanical stability. Do not connect to GND
15	/Reset & Prog 1	Digital Input – Active low reset. Bring low for >10 mS to reset device. If not used, solder to open circuit for mechanical stability. Do not connect to GND. Also used for FLASH programming.
16	Prog 2	Digital Input – If not used, solder to open circuit for mechanical stability. Do not connect to GND. Also used for FLASH programming.
17	NC	Solder to open circuit for mechanical stability. Do not connect to GND
18	NC	Solder to open circuit for mechanical stability. Do not connect to GND

***Note:** Grey boxes indicate that a signal is available only on a custom application basis. NC means “no connection”.

SQ-SI2X-360DA SERIES PACKAGE

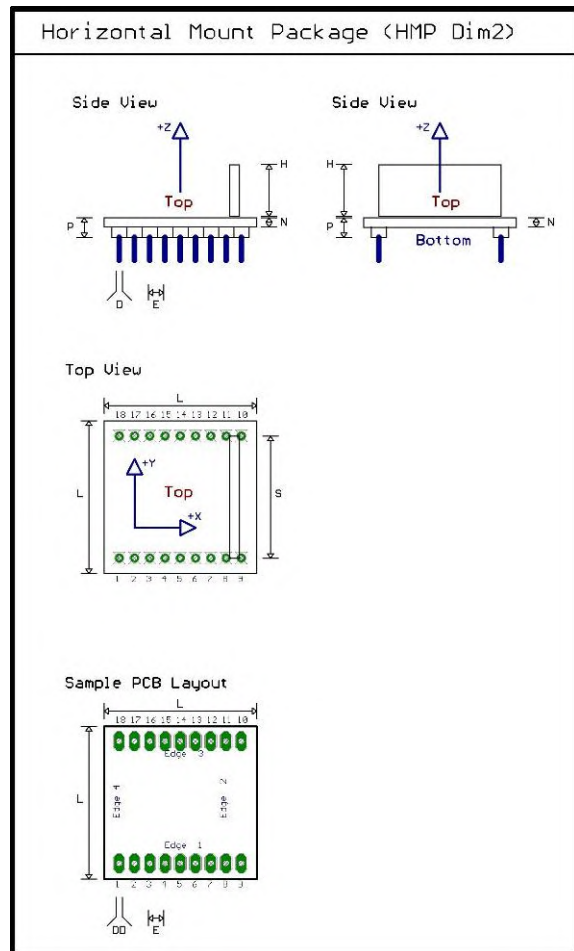

DIMENSIONS

DIMENSION	MILLIMETERS	INCHES	DESCRIPTION	NOTES
T	10.16	0.40	N/A	Pin center to center
L	25.40	1.00	Side length	
E	2.54	0.10	Pitch	Pin center to center
D	0.80	0.032	Pin diameter	
DD	1.00	0.040	Hole diameter	
N	1.63	0.064	PCB thickness	
H	8.64	0.34	Ortho board height	
P	3.30	0.13	N/A	
S	20.32	0.80	Pin row spacing	Same as ortho board width

DESIGN, LAYOUT, AND ASSEMBLY CONSIDERATIONS

1. Since the device is a subassembly of surface mount components, it is not suitable for automatic assembly or wave soldering.
2. Hand soldering of pins or SMT pads is specified for 3 seconds at 218 °C.
3. Pins labeled NC (no connect) should be soldered to open connection pads / pins for mechanical stability.
4. The designer should test the device's output voltage through its entire desired angle range during prototyping to ensure that it is working properly in the application.

SERIAL INTERFACE: HP AND LP VERSIONS*

UART FORMAT: 8-N-1

8 data bits, 1 stop bit, no parity, no flow control: 115,200 baud or 57,600 baud, pin-selectable. (Available in 19,200 baud by special order.)

One byte commands can be sent from the host to control various functions of the device. The following commands can be sent to the devices via the UART. The data encoding is HEX, not ASCII.

INTERROGATE

0x01 (Interrogate Mode command)

The inclinometer responds with one data packet [10 bytes] after receiving the Interrogate Mode command. The maximum delay between a request and the data packet response is 1 Update Period. The host should not issue a new Interrogate Mode command before it has received a response to a previous Interrogate Mode command.

STREAM

0x02 (Stream Mode command)

The inclinometer begins sending data packets [10 bytes] continuously at the given Update Rate. The maximum delay between a request and the first data packet response is one Update Period.

RESET

0x83 (Reset command)

The inclinometer initiates its Power-on Reset sequence (see Power-on Reset below).

POWER-ON RESET AND RST PIN

When the inclinometer is disconnected from power it reverts to its default settings in Interrogate Mode. It transmits 1 data packet [10 bytes] after its Warm Up time to indicate that measurements are stabilized.

* For the ULP version see the document "SQ-SI2X ULP Addendum" available at <http://www.signalquest.com>

SERIAL PACKET FORMAT: HP AND LP VERSIONS

	BYTE	TILT MODE	GIMBALED MODE	NOTES
Header	0	Sync byte 1	Sync byte 1	0xFE
	1	Sync byte 2	Sync byte 2	0xFE
Payload	2	X Tilt (high byte)	Y Rotation (high byte)	Format: 16-bit, unsigned integer <i>Output_Value = Measured_Angle × 10.</i> For example, a measured angle of 127.5 ° results in an output value of 1275.
	3	X Tilt (low byte)	Y Rotation (low byte)	
	4	Y Tilt (high byte)	Y Tilt (high byte)	
	5	Y Tilt (low byte)	Y Tilt (low byte)	
	6	Factory	Factory (high byte)	Undefined
	7	Factory	Factory (low byte)	
Checksum	8	Checksum (high)	Checksum (high)	Format: 16-bit, unsigned integer sum of the 16 bit unsigned integer payload values. The checksum does not include the two sync bytes (0xFE 0xFE).
	9	Checksum (low)	Checksum (low)	

EXAMPLE OUTPUT: HP AND LP VERSIONS*

EXAMPLE SUPPLY VOLTAGE		
+V _{cc}	3.300	V
Sensitivity	0.01289	V/bit
Scale factor	0.00731	V/deg
Offset value	0.3300	V
Max value	2.9552	V

EXAMPLE ANGLES	OUTPUT (BITS)	OUTPUT (V)
0	26	0.335
10	31	0.399
20	37	0.477
30	43	0.554
40	48	0.618
50	54	0.696
60	60	0.773
70	65	0.837
80	71	0.915
90	77	0.992
100	82	1.057
110	88	1.134
120	94	1.211
130	99	1.276
140	105	1.353
150	111	1.430
160	116	1.495
170	122	1.572
180	128	1.650
190	133	1.714
200	139	1.791
210	145	1.869
220	150	1.933
230	156	2.010
240	162	2.088
250	167	2.152
260	173	2.230
270	179	2.307
280	184	2.371
290	190	2.449
300	196	2.526
310	201	2.591
320	207	2.668
330	213	2.745
340	218	2.810
350	224	2.887

Angle vs. Output Voltage

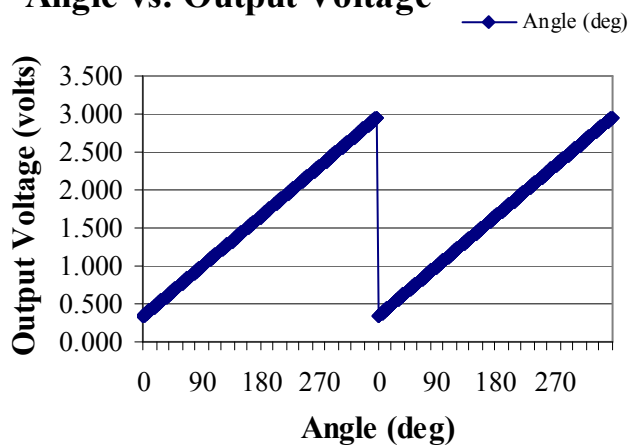

* For supply voltages other than 3.3V see the document "Inclinometer Worksheet" available at <http://www.signalquest.com>

ORIENTATION

TERMINOLOGY

Gravity means a vector pointing from the device toward the center of the earth.

X means a vector parallel to the white silkscreen arrow “X” printed on the main circuit board.

Y means a vector parallel to the white silkscreen arrow “Y” printed on the main circuit board.

Z means a vector passing through the white silkscreen dot “Z” printed on the main circuit board, at 90° to the board.

Horizontal means the silkscreen arrow is pointing at a right angle to gravity.

Straight Down means the silkscreen arrow is parallel to gravity.

Straight Up means that the silkscreen arrow is anti-parallel to gravity (i.e. pointing toward the sky).

Plumb Line is a line with a weight on the end hanging straight down.

TILT MODE

In Tilt Mode the X Tilt and Y Tilt angles are measured between gravity and the white silkscreen arrows printed on the main circuit board. If you passed a Plumb Line through the inclinometer’s X, Y, Z origin, the X and Y Tilt angles could be measured by placing a protractor’s straight edge on the plum line and then reading the angles made with each arrow.

Y Tilt = Pitch (first angle)

X Tilt = Roll (second angle)

Holding Y Horizontal

When X is Horizontal and Z is Straight Up, X Tilt = 90°.

When X is Horizontal and Z is Straight Down, X Tilt = 270°.

When X is Straight Up, X Tilt = 180°.

When X is Straight Down, X Tilt = 0 / 360°.

Holding X Horizontal

When Y is Horizontal, Y Tilt = 90°.

When Y is Straight Up, Y Tilt = 0°.

When Y is Straight Down, Y Tilt = 180°.

GIMBALED MODE

In both Tilt Mode and Gimbaled Mode, the Y Tilt measurement is identical. However, in Gimbaled Mode, the Y Rotation angle is defined as a rotation *about* the Y axis of the device. You will find that this is similar to X Tilt (in Tilt Mode) when near horizontal, but further from horizontal, the difference between these two measurement methods is quite pronounced.

For users familiar with Euler Angles, this measurement mode is equivalent to performing the Euler X-Y transformation on the Tilt Mode coordinates, and then adjusting the quadrants to be continuous. In Gimbaled Mode unlike Tilt Mode, there will be no numerical discontinuities near 0 and 180 degrees for X Tilt, when Y is not Horizontal.

IMPORTANT NOTES

- Tilt Mode angles are not generally equivalent to Gimbaled Mode angles. Tilting X up or down in the Tilt Mode coordinate system is not equivalent to making a rotation about the Y axis unless Y is fixed horizontally. The same is true for the X axis. Consult SignalQuest technical support and reference material on orientation reference frames.
- Users wanting to measure rotations about the inclinometer’s Y axes rather than tilt angle with respect to gravity, should use the Gimbaled Mode coordinate system. To convert a dataset from Tilt Mode coordinates (the sensor’s native output) to Gimbaled Mode coordinates, contact SignalQuest for application notes and sample software.

(continued on following page)

SQ-SI2X-360DA**SOLID-STATE WIDE RANGE MEMS INCLINOMETER**360 ° X 180 ° DUAL AXIS, SERIAL AND ANALOG OUTPUT

- Regardless of the coordinate frame used the inclinometer measures angles with respect to gravity. It cannot measure rotation about the gravity vector. All rotations about gravity are *invisible* to the sensor and are considered equivalent.

SQ-SI2X-360DA

SOLID-STATE WIDE RANGE MEMS INCLINOMETER
360° X 180° DUAL AXIS, SERIAL AND ANALOG OUTPUT

Ordering Guide

OPTIONS	CODE	OPTION	NOTES
Power regulator option	-NR	No onboard regulator	Special order only
	-3.0R	3.0 V onboard regulator	Special order only
	-3.3R	3.3 V onboard regulator	Standard version (stock)
Pin package option	-HMP	Horizontal mount package	Fits into standard 0.100" grid circuit board
	-VMP	Vertical mount package	Available for SQ-SI family only
	-NP	No pins installed	Fits inside potting box enclosures (SQ-ENCL-1)
Performance option	-HP	High performance	Better if power consumption is not a primary concern
	-LP	Low power	Better if low power consumption is critical
	-ULP	Ultra low power	Pre-release version available now
Accuracy	-IND	High accuracy	Suitable for industrial applications needing precise measurement
	-LC	Low cost	Suitable for high volume, lower accuracy, cost sensitive applications
Damping option (used for HP and LP version only)	-S	500 mS settling time	Better noise rejection, slower response time – This model uses a 0.5 second moving average filter to provide digital damping. This reduces the impact that spurious accelerations and vibrations have on the angle reading. This model will reject noise better than the “F” model, but with the trade off of a slower response time.
	-F	100 mS settling time	Faster response time, poorer noise rejection – This model uses a 0.1 second moving average filter to provide digital damping. This model will respond more quickly to changes in angle than the “S” model, but with the tradeoff of poorer noise rejection.
RoHS (lead free)	-E	RoHS complaint, lead free	
Other option	-Custom	Customer-specific requirements	Please contact SignalQuest if you require an option not listed in this table. For example, various baud rates, setting times, update rates and voltage regulator options may be available on request.

***Note:** “S” and “F” options only apply to HP and LP versions.

EXAMPLE PART NUMBER

SQ-SI2X-360DA-3.3R-HMP-IND-HP-S

SQ-SI2X-360DA**SOLID-STATE WIDE RANGE MEMS INCLINOMETER**

360° X 180° DUAL AXIS, SERIAL AND ANALOG OUTPUT

ACCESSORIES

PART NUMBER	DESCRIPTION
SQ-USB2-TTL	<ul style="list-style-type: none">Self-powering USB cable used to directly connect device to a PC.Installs a “virtual COM port” on host PC (i.e. COM 3).Converts PC voltage levels to device voltage levels and supplies power.Allows multiple devices to be easily connected to a single computer.Compatible with SignalVIEW real time display and data logging software.DLL provided for custom application development in VC++, C#, VB etc...
SQ-RS232-TTL	<ul style="list-style-type: none">Same as above cable, but external power is required for devices without –LP option.
SQ-ENCL-1	<ul style="list-style-type: none">Potting box enclosure. Fits models without pins installed (-NP option). Order one if using SQ-SI family or two if ordering SQ-SI2X family.



SQ-SI2X-360DA

SOLID-STATE WIDE RANGE MEMS INCLINOMETER

360° X 180° DUAL AXIS, SERIAL AND ANALOG OUTPUT

LIMITATIONS AND WARNINGS

LIFE SAFETY

This product is not designed for use in life support and/or safety equipment where malfunction of the product can reasonably be expected to result in personal injury or death. Buyer uses this product in such applications at Buyer's own risk and agrees to defend, indemnify, and hold harmless SignalQuest, Inc. from any and all damages, claims, suits, or expenses resulting from such misuse.

DYNAMIC ENVIRONMENTS

The device is designed to be used to measure angles in a quasi-static environment where external vibrations and accelerations are kept to a minimum. Digital and analog signal processing methods are employed to reduce the effects of transient acceleration and small vibrations on the angle reading; however, under dynamic conditions where external accelerations or vibrations are present, the sensor's performance may be degraded.

VARIATIONS IN EARTH'S GRAVITY

This device is designed to be used near the earth's surface only. Substantial changes in gravity will degrade the performance of the sensor. This device is not intended or qualified to be used in aviation.

TESTING

The performance of each system is verified through build-time testing. Each system is tested before and after factory calibration to ensure reliable performance.

SYSTEM INTEGRATION TESTING

Thorough testing should be carried out prior to product release to ensure system integration has not introduced unforeseen problems. The system integrator assumes the ultimate responsibility for the safety of the target application.

NOTICE

Information furnished by SignalQuest, Inc is believed to be accurate and reliable. However, this document may contain ERRORS and OMISSIONS. Accordingly, the design engineer should use this document as a reference rather than a strict design guideline and should perform thorough testing of any product that incorporates this or any other SignalQuest product. No responsibility is assumed by SignalQuest, Inc. for this use of this information, or for any infringements of patents or other rights of third parties that may result from its use. Specifications are subject to change without notice. No license is granted by implication or otherwise under any patent or patent rights of SignalQuest, Inc. Trademarks and registered trademarks are the property of their respective companies.

FURTHER INFORMATION

For pricing, delivery, and ordering information, please contact SignalQuest at (603) 448-6266
For updates on this and other documents, visit our website at www.signalquest.com