



### DESCRIPTION

The NorthPoint™ AHRS provides a fast dynamic 6 degree of freedom (6 DOF) positioning solution in the presence of high shock, magnetic interference, acceleration and vibration.

The system employs dual frequency, multi constellation RTK GNSS coupled with high-stability temperature compensated ceramic packaged MEMS accelerometers and gyroscopes for excellent long-term performance and reliability.

The RTK GNSS INS and active antenna are fully integrated in an extremely rugged waterproof housing, greatly simplifying system architecture and increasing overall reliability.

Multiple sensors can be daisy chained together on the CAN bus to create large measurement systems.

### KEY FEATURES

- **Static and Dynamic Heading**
- **3D position, Pitch, Roll, Yaw**
- **Fully integrated GPS, INS and Antenna**
- **Configurable as Rover or Base**
- **RTCM Corrections through CAN Bus**
- **Daisy Chain Sensors**
- **Bluetooth LE 5.2, 1000 m range**

### MEASUREMENTS

- **IMU (3-axis acceleration and rotation)**
- **X, Y, Z position**
- **X, Y, Z velocity**
- **Pitch, Roll, Heading**

### OUTPUT OPTIONS

- CAN bus (J1939, CANOpen, and custom)

### SPECIFICATIONS OVERVIEW

Parameter	Specification
Measurement axes	6 degrees of freedom (6DOF)
Relative position accuracy	0.7 cm (1-sigma, horizontal)
Dynamic orientation angle accuracy (pitch, roll, yaw)	0.1° (1-sigma, 1-meter baseline)
Shock, acceleration and vibration use conditions	<ul style="list-style-type: none"> <li>▪ 1 gRMS random vibration 5 Hz to 500 Hz</li> <li>▪ 1 g acceleration 1 second</li> <li>▪ 20 g ½ sin 10 mSec</li> <li>▪ 100 g ½ sin 0.1 mSec</li> </ul>
Output rate	100 Hz (coupled GPS + INS), 10 Hz (GPS alone)
Temperature range	-40 ° to 85 ° C
Voltage	5 – 36 V
Current	75 mA typ. @ 13.6 VDC
Protection	IP68/69K

### DESIGNED FOR HEAVY VEHICLES

- Technology leader and market leader - SignalQuest produces more dynamic inclinometers than all competitors combined
- Primary tier 1 supplier to more than half of the world's leading heavy vehicle OEMs
- Specifically designed, tested, and qualified to meet the unique environmental operating requirements of commercial, construction, military, agricultural and mining vehicles.



**TABLE OF CONTENTS**

Description.....	1
Key Features .....	1
Measurements .....	1
Output Options.....	1
Specifications Overview .....	1
Designed for Heavy Vehicles.....	1
Communication Protocol .....	3
Parameter Group Numbers .....	4
Data Group Messages .....	5
Satellite Messages.....	6
AUTO SURVEY IN Mode .....	8
SURVEY IN Status Message .....	8
Configuration and Control Messages.....	9
Sensor Configuration and Control Message [PGN 61184 (0x00EF00)].....	9
GPS Request/Reply Configuration and Control Message [PGN 126720 (0x01EF00)].....	12
System Commissioning .....	16
Absolute Maximum Ratings .....	19
Electrical Characteristics .....	19
Dynamic Performance .....	19
Connector Diagram.....	20
Pin Descriptions.....	20
Measurement Definitions.....	22
Package Dimensions.....	23
Limitations and Warnings .....	24
Revision Table SQ-NPG-0021 .....	24

## COMMUNICATION PROTOCOL

This sensor communicates using a protocol based on SAE J1939. This section describes only those aspects of SAE J1939 that pertain to this sensor.

On a J1939 network, each device (Electronic Control Unit, or ECU) is assigned a unique 8-bit address, ranging from 0 to 253. Address 249 is reserved for Diagnostic Tools, 252 is reserved for Experimental Use, 254 is reserved for network management, and the address 255 is reserved as the Global Address that all devices listen to. Note that a device may contain more than one Unit, with each Unit responding to different addresses, but this sensor contains only one Unit.

The J1939 8-bit address is normally assigned as part of an address claim procedure. The address claim procedure of this sensor differs slightly from that used by J1939, as described in this document.

The J1939 8-bit address is used as part of the 29-bit CAN ID used to transmit packets on the bus. For each message, the complete 29-bit field of the CAN ID consists of a 3-bit priority, an 18-bit Parameter Group Number (PGN), and the 8-bit address of the ECU transmitting the message (the Source Address).

### J1939 CAN ID format

28	27	26	25	24	23	22	21	20	19	18	17	16	15	14	13	12	11	10	9	8	7	6	5	4	3	2	1	0
Priority (0 ~ 7)			Parameter Group Number (PGN) (18 bits)																		Source Address of this message (8 bits, 0 ~ 255)							

The priority field controls the CAN arbitration. If two or more devices attempt to transmit on the bus simultaneously, the device with the lower CAN ID will win arbitration. The losing devices will re-try the transmission at the next available idle time. The three priority bits, being the most significant bits of the CAN ID provide the first opportunity specify the priority of a message in the arbitration scheme.

The PGN field in the message identifies the type of message, whether it is being transmitted to a single ECU, or being broadcast to all, and when being sent to a single ECU, contains the address of the destination ECU.

The Source Address is generally the address of the device sending the message. The Source Address may be 254 (0xFE) for network management purposes if no address has been successfully claimed.

There are two general types of PGN, designated as Protocol Data Units (PDU's), PDU1 or PDU2. PDU1 message are generally addressed to a specific ECU on the bus, PDU2 messages are broadcast for any ECU that is interested. Note that a PDU1 type can also be broadcast to all listeners, by sending the Destination Address as 0xFF.

### J1939 18-bit PGN format

17	16	15	14	13	12	11	10	9	8	7	6	5	4	3	2	1	0
0	DP	PDU Format (PF), 8 bits								PDU Specific (PS), 8 bits							
0	0	0x00 ~ 0xEE: PDU1 (destination-specific) defined by SAE								Destination Address (DA), or 0xFF to broadcast to all							
0	0	0xEF: PDU1 (destination-specific) defined by manufacturer								Destination Address (DA), or 0xFF to broadcast to all							
0	0	0xF0~0xFE: PDU2 (broadcast) defined by SAE								(Low 8 bits of 16-bit PDU2 code)							
0	0	0xFF: PDU2 (broadcast) defined by manufacturer								(Low 8 bits of 16-bit PDU2 code)							
0	1	0x00 ~ 0xEE: PDU1 (destination-specific) defined by SAE								Destination Address (DA), or 0xFF to broadcast to all							
0	1	0xEF: PDU1 (destination-specific) defined by manufacturer								Destination Address (DA), or 0xFF to broadcast to all							
0	1	0xF0~0xFE: PDU2 (broadcast) defined by SAE								(Low 8 bits of 16-bit PDU2 code)							
0	1	0xFF: PDU2 (broadcast) defined by manufacturer								(Low 8 bits of 16-bit PDU2 code)							

DP = Data Page, there are two pages of PGN's that follow these same guidelines. This sensor uses both Data Page 0 and Data Page 1.

When PGN's are documented, the convention is to express the PGN as a 24-bit number, with the high 6 bits being 0. For type PDU1, the PGN number is represented with the low 8 bits (the destination address) as 0. For type PDU2, the PGN number is represented with all significant 18 bits.

For SAE-defined PGN's, the complete format of the message, including which parameters are transmitted, how the data is encoded, how often the message is transmitted, and which bits in the CAN 64-bit field are used by each parameter, are all predefined. Each parameter that appears in an SAE-defined message is assigned a Suspect Parameter Number (SPN), and SAE maintains a complete database of SPN's and their mappings into SAE-defined PGN's.

## PARAMETER GROUP NUMBERS

This sensor transmits several types of messages:

- **Data Group:** 13 Messages/Group, One Group per Rover. Output Rate depends on Configuration, typically 10 Hz.
- **Satellite Messages:** A message is transmitted once per second; each one-second message contains information about one detected satellite. A special Satellite Summary Message is sent at the beginning of each group of Satellite messages. The Number of Satellite messages transmitted depends on the number of Satellites the GPS is currently tracking. Note that some satellites not currently used to compute the Navigation Solution can be reported.
- **Replies** to various Configuration Commands, (including J1939 Acknowledgments).
- Also **bursts of CAN traffic** occur once per second from the 'Base' sensor which broadcasts RTCM aiding messages from the Base and is monitored by the Rovers. These messages use J1939 Transport Protocol (TP) multi-packet format. The burst can contain 5 or more multi-packet messages, each message up to 400 bytes or more. (Most messages are smaller, typically this entire message stream comprises approximately 90-120 64-bit CAN frames.)

### J1939 PGNs used by this device:

Purpose	PGN	Type	Notes
RTCM Aiding Burst	43008* (0x00A800)	PDU1	Used to send RTCM aiding bursts. Uses multi-packet TP (Transport) Protocol.
J1939 Acknowledgment (SAE-defined)	59392 (0x00E800)	PDU2	Used for Acknowledgment of a J1939 message. Always broadcast to the J1939 Global Address (0xFF)
Request for PGN (SAE-defined)	59904 (0x00EA00)	PDU1	Used to request claimed addresses from all ECUs. Broadcast to all (DA = 0xFF), request PGN 60928.
Transport Connection Data (SAE-defined)	60160 (0x00EB00)	PDU1	Used to send multi-packet TP protocol messages (Commanded Address and periodic RTCM aiding bursts).
Transport Connection Management (SAE-defined)	60416 (0x00EC00)	PDU1	Used for multi-packet TP protocol Connection Management.
Address Claimed or Address Claim Fail (SAE-defined)	60928 (0x00EE00)	PDU1	Always broadcast Globally (DA = 0xFF), on priority 6. Source Address is 254 (0xFE) to signal failure.
Sensor Configuration and Control (Manufacturer-defined)	61184 (0x00EF00)	PDU1	Sent to the sensor to configure or control and sent by the sensor to acknowledge or report current settings.
Commanded Address (SAE-defined)	65240* (0x00FED8)	PDU2	Sent using multi-packet TP (Transport) Protocol.
Data Group Messages (Manufacturer-defined)	65280 (0x00FF00) through 65292 (0x00FF0C)	PDU2	A group of 13 messages sent at one of several selectable rates, typically 10 Hz, containing all measurements.
Satellite Messages (Manufacturer-defined)	65296 (0x00FF10)	PDU2	Satellite messages are transmitted once per second. Each second, information is transmitted for one satellite.
GPS SURVEY IN Status Message (Manufacturer-defined)	65312 (0x00FF20)	PDU2	Broadcast only while a GPS SURVEY IN operation is in progress.
Diagnostic Messages	65408 (0x00FF80)	PDU2	Rarely generated proprietary diagnostic messages.
GPS Request/Reply Configuration and Control (Manufacturer-defined)	126720 (0x01EF00)	PDU1	Sent to the sensor to configure or control and sent by the sensor to acknowledge or report current settings.

\* PGN's marked with an asterisk are transmitted within a multi-packet J1939 TP protocol connection management message, and the PGN does not appear as part of the CAN message ID but is located within the body of the J1939 TP protocol Connection Management packets.

Manufacturer defined messages are described in further detail in the following sections.

## DATA GROUP MESSAGES

This sensor transmits its measurements in a group of 13 messages, back-to-back, typically at a 10Hz rate. The messages in the group will be queued for transmission but may be delayed by higher priority traffic on the CAN bus, and messages from other devices may be interleaved due to priority. Each group is sent in order and consists of the following messages:

J1939 PGN	CAN Message ID	Name	Data Field
65280	0x18FF00nn	Header Message	Byte 1: Group Counter (Increments from 0 to 255 and rolls over) Byte 2: Valid/Stale Bit Mask (bit clear indicates stale or invalid data) Bit 0: High Precision Latitude (PGN 65281) Bit 1: High Precision Longitude (PGN 65282) Bit 2: High Precision Height (PGN 65283) Bit 3: Relative North (PGN 65284) Bit 4: Relative East (PGN 65285) Bit 5: Relative Down (PGN 65286) Bit 6: Relative Base Line Length (PGN 65287) Bit 7: Relative Heading (PGN 65288) Byte 3~8: UTC time, derived from GPS Time unsigned 48-bit integer in Seconds x10 <sup>3</sup>
65281	0x18FF01nn	High Precision Latitude	Byte 1~8: signed 64-bit integer, in degrees x10 <sup>9</sup> , negative is South.
65282	0x18FF02nn	High Precision Longitude	Byte 1~8: signed 64-bit integer, in degrees x10 <sup>9</sup> , negative is West.
65283	0x18FF03nn	High Precision Height	Byte 1~8: signed 64-bit integer, in meters x10 <sup>4</sup> .
65284	0x18FF04nn	Relative North	Byte 1~4: Relative North pos, signed 32-bit integer in meters x10 <sup>4</sup> , negative is South. Byte 5~8: reserved
65285	0x18FF05nn	Relative East	Byte 1~4: Relative East pos, signed 32-bit integer in meters x10 <sup>4</sup> , negative is West. Byte 5~8: reserved
65286	0x18FF06nn	Relative Down	Byte 1~4: Relative Down pos, signed 32-bit integer in meters x10 <sup>4</sup> , negative is Up. Byte 5~8: reserved
65287	0x18FF07nn	Relative Base-Line Length	Byte 1~4: Relative Length, signed 32-bit integer in meters x10 <sup>4</sup> . Byte 5~8: reserved
65288	0x18FF08nn	Relative Heading	Byte 1~4: Heading, signed 32-bit integer, in degrees x10 <sup>5</sup> , 0° is North. Byte 5~8: reserved
65289	0x18FF09nn	Accelerometer	Byte 1~2: X-accel, signed 16-bit integer, in g's x10 <sup>3</sup> . Byte 3~4: Y-accel, signed 16-bit integer, in g's x10 <sup>3</sup> . Byte 5~6: Z-accel, signed 16-bit integer, in g's x10 <sup>3</sup> . Byte 7~8: reserved
65290	0x18FF0Ann	Angular Rates (Gyros)	Byte 1~2: X-gyro, signed 16-bit integer, in deg/sec x10 <sup>1</sup> . Byte 3~4: Y-gyro, signed 16-bit integer, in deg/sec x10 <sup>1</sup> . Byte 5~6: Z-gyro, signed 16-bit integer, in deg/sec x10 <sup>1</sup> . Byte 7~8: reserved
65291	0x18FF0Bnn	Pose	Byte 1~2: Elevation, signed 16-bit integer, in degrees x10 <sup>1</sup> . Byte 3~4: Roll, signed 16-bit integer, in degrees x10 <sup>1</sup> . Byte 5~8: reserved

J1939 PGN	CAN Message ID	Name	Data Field
65292	0x18FF0Cnn	Trailer/Status	Byte 1: Group Counter (Increments from 0 to 255 and rolls over) Byte 2: Current Number of Satellites in use Byte 3~4: DOP (Dilution of Precision) x10 <sup>2</sup> Byte 5: Reserved Byte 6: Status flags: Bit 0: Differential Mode 1 = GPS is being aided with Differential Corrections Bit 1: Valid Fix 1 = Valid Bit 2~3: RTK Ambiguity 0 = No RTK 1 = Float RTK operation 2 = Fixed RTK operation Bit 4~7: GPS Fix Type 0~1 = No Fix 2 = 2D Fix 3 = 3D Fix 4 = GNSS 5 = Fixed Base Mode (aka 'Time Only') Fix Byte 7: Status flags: Bit 0~1: Reserved Bit 2: Survey In Failed 1 = Survey In Operation Failed Bit 3: Survey In Position Valid 1 = Survey In Operation Completed Bit 4: Survey In Busy 1 = Survey In Busy Bit 5: Reserved Bit 6: Position Valid 1 = Relative North, East and Down Position is valid Bit 7: Valid Time 1 = UTC Time is Valid (Derived from GPS Time) Byte 8: Reserved

Note that all multi byte values are Least Significant Byte first.

## SATELLITE MESSAGES

Satellite information is collated internally in the sensor and reported for each active satellite, with one message being transmitted each second representing one satellite. Since a typical configuration would use 15 to 25 satellites, it will take 15 to 25 seconds to report all satellite information from a sensor. Note that more satellites will be reported than are used in the Navigation solution. These additional satellites are known to the receiver but are not being used due to weak signals or other reasons. Bit 5: (Satellite Used, 1 = Used for Position solution) in the Individual Satellite Summary Message indicates whether the satellite was used to calculate the Navigation Solution.

One additional summary message is transmitted with a reserved Satellite Number/Constellation identifier ('0') that contains the number of Satellites, and other information about the status and quality of the GPS solution.

### Satellite Summary Message

J1939 PGN	CAN Message ID	Name	Data Field
65296	0x18FF10nn	Satellite Messages	Byte 1: Satellite Identifier. NOTE: Satellite Identifier '0' is reserved to indicate a Satellite Summary Message with a different layout. Byte 2: Number of Satellites in use Byte 3-4: Horizontal Dilution of Precision, HDOP Byte 5-8: Reserved

Note that all multi byte values are Least Significant Byte first.

### Individual Satellite Message

J1939 PGN	CAN Message ID	Name	Data Field
65296	0x18FF10nn	Satellite Messages	Byte 1: Satellite Identifier, (use with Constellation field from Status) Satellite Identifier '0' is reserved to indicate a Satellite Summary Message. See Satellite Summary Message Description. Byte 2: Carrier to Noise ratio (C/No in dBHz) Byte 3: Elevation (signed +/-90 Degrees) Byte 4-5: Azimuth (signed 0-360 Degrees) Byte 6-7: Status flags Bits 0-3: Constellation: 0: GPS 2: Galileo 3: BeiDou 6: GLONASS Bit 4: Satellite Health, 1 = Healthy Bit 5: Satellite Used, 1 = Used for Position solution Bit 6: Satellite Differential, 1 = Differential Corrections used Bit 7: Satellite RTCM, 1 = Using RTCM Corrections Bits 8-10: Signal Status: 0: No signal 1: Searching 2: Acquired 3: Unusable 4-7: Locked Bits 11-15: Reserved Byte 8: Reserved

Note that all multi byte values are Least Significant Byte first.

### Satellite Message Numbering

Satellite Identifier	Constellation Identifier	Constellation	SV (Satellite Vehicle)	Note
0	N/A	N/A	N/A	See Satellite Summary Message description.
1-32	0	GPS	G1-G32	
33-64	3	BeiDou	B6-B37	
65-96	6	GLONASS	R1-R32	
120-158	1	SBAS	S120-S158	[SBAS is an aiding system, not a navigation satellite.]
159-163	3	BeiDou	B1-B5	
193-197	5	QZSS	Q1-Q10	[QZSS is an aiding system, not a navigation satellite.]
211-246	2	Galileo	E1-E36	
255	6	GLONASS	R?	

The individual Satellite Status message contains the Satellite Identifier (1<sup>st</sup> column) and the Constellation (2<sup>nd</sup> column).

## **AUTO SURVEY IN MODE**

The Sensor provides an Auto Survey In feature that eases commissioning of a system. This mode automatically performs the steps necessary to: Self Survey the Location of the Base; Save those coordinates in both ECEF and LLH formats and automatically program the Base to operate in either FIXED BASE (ECEF) or FIXED BASE (LLH) mode.

The SURVEY IN operation is started by composing a **SURVEY IN (ECEF)** or **SURVEY IN (LLH)** Request message. The Sensor will reconfigure from the mode it is currently in and start a **SURVEY IN** operation. It will also generate a J1939 Acknowledgement message. Additionally, the SURVEY IN Busy bit is set in both the Trailer/Status message and the SURVEY IN Status message.

If the SURVEY IN Request is reissued while a SURVEY IN operation is in progress, the Survey will restart using the new parameters for Desired Accuracy and minimum Duration.

Note that a SURVEY IN operation can require an indefinite amount of time to complete, due to the requirement to meet both Accuracy and Duration. (Duration can be set to as much as 4660 hours!)

Once the SURVEY IN operation achieves at least the Desired Accuracy and the minimum Duration, the operation ends and sets the SURVEY IN Valid bit in both the Trailer/Status message and the SURVEY IN Status message.

If the Survey fails for any reason (for instance, the system is rebooted, the Mode is changed, the Device Address or Base Address are changed, etc.) the SURVEY IN Failed flag bit will be set in both the Trailer/Status message and the SURVEY IN Status message.

(NOTE: In most cases of a SURVEY IN failure, the SURVEY IN Status message will stop being transmitted. In certain unusual situations such as a power failure during a Survey In operation, the system may reboot and still transmit SURVEY IN Status messages even though the Survey In operation is no longer in progress. In this situation the SURVEY IN Failed bit will be set.)

## **SURVEY IN STATUS MESSAGE**

This message is broadcast only while a SURVEY IN operation is in progress, after setting the GPS Mode to SURVEY IN (ECEF) or SURVEY IN (LLH).

The Survey completes when both the Survey Accuracy and minimum Duration (specified when starting the Survey) are met, or the GPS mode is changed from SURVEY IN to either ROVER or FIXED BASE.

The SURVEY IN Busy bit will be set while the Survey operation is in progress.

The SURVEY IN Valid bit will be set when the Survey completes.

The SURVEY IN Failed bit will be set if the Survey Fails, usually due to a power failure, Mode change, or Device or Base Address change.

Survey results are ECEF and LLH coordinates that satisfy the values specified for Accuracy and Duration when the Survey was initiated using the SURVEY IN Request.

Survey results can be read using the SURVEY IN RESULT Request(s).

The SURVEY IN mode operation ends when both the required Accuracy and Duration are met, or the GPS mode is changed.



### SURVEY IN Status Message

J1939 PGN	CAN Message ID	Name	Data Field
65312	0x18FF20nn	SURVEY IN Status Message	<p>This message is broadcast only while a GPS SURVEY IN operation is in progress, after setting the GPS Mode to SURVEY IN. It will continue to be broadcast until the GPS mode changes to either ROVER or FIXED BASE.</p> <p>Bytes 1~4: Estimated Position Accuracy x10<sup>4</sup> m (unsigned 32-bit value x10<sup>4</sup> m)</p> <p>Bytes 5~7: Survey Duration (unsigned 24-bit value Seconds)</p> <p>Byte 8: Status flags</p> <ul style="list-style-type: none"> <li>Bits 0~4: Reserved:</li> <li>Bit 5: SURVEY IN Failed: <ul style="list-style-type: none"> <li>1 = Survey In Operation Failed</li> </ul> </li> <li>Bit 6: SURVEY IN Valid: <ul style="list-style-type: none"> <li>1 = Survey In Operation Completed</li> </ul> </li> <li>Bit 7: SURVEY IN Busy: <ul style="list-style-type: none"> <li>1 = Survey In Progress</li> </ul> </li> </ul>

Note that all multi byte values are Least Significant Byte first.

### SURVEY IN Status Message (32/24-bit/Status) Layout [PGN 65312 (0x00FF20)]

Byte 1	Byte 2	Byte 3	Byte 4	Byte 5	Byte 6	Byte 7	Byte 8				
Value 1 (32 bit), Least Significant Byte First				Value 2 (24 bit), Least Significant Byte First			Bit 7	Bit 6	Bit 5	Bits 4-0	
							Survey In Progress	Survey In Position Valid	Survey In Failed	Reserved	

## CONFIGURATION AND CONTROL MESSAGES

There are 2 sets of Configuration and Control Commands.

The first set (Sensor Configuration and Control) are used to configure the Sensor using PGN 61184 (0x00EF00).

The second set (GPS Request/Reply Configuration and Control) are used to configure the GPS using PGN 126720 (0x01EF00).

### SENSOR CONFIGURATION AND CONTROL MESSAGE [PGN 61184 (0x00EF00)]

The Sensor Configuration and Control message is used to set or read various controls or settings of the sensor. It is transmitted using PGN 61184 (0x00EF00); and is both sent to and transmitted from the sensor.

In each message, the data field contains a 4-byte Function Code, and up to 4 bytes of data.

The data field in the message will always contain 8 bytes. Even if fewer bytes are needed, the remaining unused bytes should still be included in the message.

### Data Field of PGN 61184 [0x00EF00] Sensor Configuration and Control Message

Byte 1	Byte 2	Byte 3	Byte 4			Byte 5	Byte 6	Byte 7	Byte 8
Function Code (High bit set to Write a value)				Data Field (Always 4 bytes, unused bytes are 0)					
Index			R/W	000	Size	LSB	...	...	MSB

Note that all multi byte values are Least Significant Byte first.

When sending a message to the sensor, if the Function Code (composed of the Index, Size and R/W bits) accesses a setting that may be read or written, the high bit (R/W bit) of Function Code Byte 4 controls whether the message is to write the value

(high bit set) or read the value (high bit clear). In practice this means adding 0x80 to the Function Code (Byte 4) when Writing a value, (or setting the R/W bit if you have your messages mapped that way).

The low 4 bits (Size Field) of Byte 4 of the Function Code determine the size of the value to be read or written. The supported sizes are 1, 2, 4 and 8 bytes. (Note that the reserved value of '0' bytes is used for certain commands: 'SAVE' and 'COLD'.)

Whether a value is read or written, the sensor will generate a reply that contains the current value of the setting or control. The reply has the same format. The high bit (Write bit) of the Function Code will not be set in the reply. However, no reply is generated when setting the Device Address, or when issuing any of the write-only commands.

All data is transmitted least-significant byte first.

After a setting is written, a 'SAVE' command should be issued to write the setting to non-volatile memory, so that the setting is restored the next time the sensor is power cycled. Some setting changes do not require a 'SAVE' command, see Comments in the table below.

The following table summarizes the available Sensor settings (PGN 61184). There is another Table (PGN 126720) for the GPS settings.

#### NOTES:

- J1939 CAN Message ID's are constructed by specifying the Priority, the PGN, the Destination and the Source. 'PDU1' messages are Point to Point and require both Destination and Source Addresses. 'PDU2' messages are Broadcast messages and only require/contain a Source Address.
- A J1939 CAN Message ID is: [(Priority<<26) + (PGN<<8) + (Destination<<8) + Source]. For a 'PDU2' Message, the CAN Message ID is computed with Destination equal to '0'.
- All PGN 61184 Configuration messages are 'PDU1' Point to Point messages and require both Destination and Source Addresses.
- PGN 61184 commands do not support the Global Address.

#### PGN 61184 (0x00EF00) PDU1 Sensor Configuration Commands:

Setting	PGN [Message ID*]	Function Code**	Index	R/W bit	Size	Data Range	Units	Comments
Device Address	0x18EFddss  [dd = Destination, ss = Source]	0x210014E0 0xA10014E0	0x0014E0	Read (0) Write (1)	1	0x80 ~ 0xFB Factory Default: 0xC3 or 0xC4 or 0xC5	N/A	<p>Sensor will store the new address to non-volatile memory, reboot and attempt to claim the new address, following the claim procedure described above. No other reply is generated when this value is written, instead the J1939 address claim message is transmitted.</p> <p>NOTE: It is not necessary to issue a 'Settings' command after writing this value.</p> <p>Values above 0xF7 (247) are discouraged as these are special purpose J1939 addresses.</p> <p>[NOTE: This command will accept a legacy size value of 2.]</p>
Base Address	0x18EFddss	0x210014E1 0xA10014E1	0x0014E1	Read (0) Write (1)	1	0x80 ~ 0xFB Factory Default: 0xC3	N/A	<p>BASE address is the Address that a Rover monitors to RTCM aiding broadcasts.</p> <p>If the BASE address equals the DEVICE address, the sensor becomes a BASE and will transmit RTCM aiding messages.</p> <p>Sensor will store the new address to non-volatile memory.</p> <p>NOTE: It is not necessary to issue a 'SAVE' Settings command after writing this value.</p> <p>(Values above 0xF7 (247) are discouraged as these are special purpose J1939 addresses.)</p> <p>Note that all Sensors can have their BASE address assigned simultaneously by writing to the J1939 Global Address (0xFF).</p> <p>[NOTE: This command will accept a legacy size value of 2.]</p>
Baud Rate	0x18EFddss	0x210014E4 0xA10014E4	0x0014E4	Read (0) Write (1)	1	0 ~ 3 Factory Default: 3	N/A	<p>3=250K 0=1000K Currently only 250K and 1000K supported. Requires SAVE command.</p> <p>Note that the CAN Baud Rate will not change until Power to the sensor is cycled, or the unit is software rebooted using the 'COLD' boot command.</p> <p>NOTE: It is not necessary to issue a 'SAVE' Settings command after writing this value.</p> <p>All units on the bus can have their Baud Rates changed, and the entire system can then be restarted.</p>

Setting	PGN [Message ID*]	Function Code**	Index	R/W bit	Size	Data Range	Units	Comments
Terminator	0x18EFddss	0x210014E5 0xA10014E5	0x0014E5	Read Write	1	0x00 or 0x01 Factory Default: 0x01	N/A	0x00 to ENABLE the built-in CAN terminator 0x01 to DISABLE the built-in CAN terminator  NOTE: This setting must be 'SAVE'ed, and the sensor power-cycled or reset before the terminator is enabled or disabled.
Cold Boot	0x18EFddss	0xA0FFFFFF0	0xFFFFF0	Write Only	0	"COLD" (0x43 0x4F 0x4C 0x44)	N/A	Reboots the sensor as if it were power cycled. No reply is generated when this command is sent.  Note this message uses a unique layout and message size of '0'.
Save to Non-Volatile Memory	0x18EFddss	0xA0FFFFFF0		Write Only	0	"SAVE" (0x53 0x41 0x56 0x45)	N/A	Saves all settings listed in this table, except Device Address, to non-volatile memory. No reply is generated when this command is sent.  Note this message uses a unique layout and message size of '0'.

\* The required CAN Message ID is: [(Priority<<26) + (PGN<<8) + (Destination<<8) + Source]

\*\* The Function code is the composite of the Index R/W bit and Size. [Function Code = (R/W<<31) + (Size<<24) + Index]

## GPS REQUEST/REPLY CONFIGURATION AND CONTROL MESSAGE [PGN 126720 (0x01EF00)]

### Data Field Layouts of PGN 126720 (0x01EF00) Request/Reply Messages:

The PGN 126720 Request/Reply Configuration and Control Messages are used for a variety of GPS configuration commands using Request/Reply messaging.

All Request messages receive either a Reply containing Values and Status bits or a standard J1939 Acknowledgement message.

There are 2 different Frame Layouts for the PGN 126720 Request and Reply messages: A Dual Value (24-bit) layout and a Single Value (40-bit) layout.

#### Dual Value (24-bit) Layout [PGN 126720 (0x01EF00)]

Byte 1	Byte 2	Byte 3	Byte 4	Byte 5	Byte 6	Byte 7	Byte 8		
Value 1 (24 bit), Least Significant Byte First			Value 2 (24 bit), Least Significant Byte First			Sub Index	Bit 7	Bit 6	Bits 5-0
							Read / Write Bit	Request / Reply Bit	Index

#### Single Value (40-bit) Layout [PGN 126720 (0x01EF00)]

Byte 1	Byte 2	Byte 3	Byte 4	Byte 5	Byte 6	Byte 7	Byte 8		
Value 1 (40 bit), Least Significant Byte First					Zero	Sub Index	Bit 7	Bit 6	Bits 5-0
							Survey In Busy	Survey In Position Valid	Reserved

#### J1939 Acknowledgment Message Layout [PGN 59392 (0x00E800)]

Byte 1	Byte 2	Byte 3	Byte 4	Byte 5	Byte 6	Byte 7	Byte 8
Control Byte	Group Function (Index)	Reserved by SAE (0xFFFF)		Address Acknowledged	PGN (Least Significant Byte First) PGN 126720 (0x01EF00)		

Both PGN 126720 Request and Reply message layouts contain an Index Field (containing Read/Write and Request/Reply bits), a Sub Index Field and 1 or 2 Value fields.

Composing a Request requires selecting the Index and Sub Index for the Operation desired, setting the Read/Write Bit accordingly, and making certain the Request/Reply bit is clear ('0') in Byte 8. Setting the Read/Write bit is easily accomplished by adding 0x80 to Byte 8 for a Write operation.

Some messages generate Replies containing data, which will be returned in an identical frame layout with the Reply bit set in Byte 8, other Messages are simply Acknowledged with a conventional J1939 Acknowledgment Message. A Reply bit set to '1' corresponds to adding 0x40 into Byte 8. For example, a Reply to a '0x01' Read request in Byte 8 will receive a Reply with '0x41' in Byte 8.

The sensor does not support multiple simultaneous Requests. If another Request is issued before the Reply for a previous Request is received, the sensor will issue J1939 Acknowledgment for 'Cannot Respond'. (The original Request will still be completed.)

The sensor will return either a PGN 126720 Reply message or a J1939 Acknowledgment depending on whether the operation was successful, failed, denied, or busy ('Cannot Respond').

The Control Byte of J1939 Acknowledgment will be one of:

**J1939 Acknowledgment Message Control Byte Values**

Control Byte	Meaning
0	Positive Acknowledgment
1	Negative Acknowledgment
2	Access Denied
3	Cannot Respond

Note that J1939 Acknowledgment Messages are always sent to the J1939 Global Address (0xFF). The Address of the Requester is in Byte 5 of the J1939 Acknowledgment Message.

**PGN 126720 (0x01EF00) PDU1 Request/Reply Commands: (Index, Sub Index and Value(s))**

Index	Sub Index	R/W	Values 1 & 2	Units	Comments
GPS MODE	1 ROVER MODE*	1 R/W	N/A		<p><b>ROVER</b> Mode is the normal operating mode for all Sensors other than a <b>FIXED BASE</b>.</p> <p>A Read Request to <b>ROVER MODE</b>, <b>SURVEY IN MODE</b>, or <b>FIXED BASE MODE</b> will return the current Sensor GPS Mode in the Index Value and additionally will return the current Estimated Position Accuracy in Value 1 if the sensor is in <b>FIXED BASE</b> operation, or the Required Accuracy and Duration if the sensor is in <b>SURVEY IN</b> mode in Value 1 and Value 2.</p> <p>Note that setting a Sensor to <b>ROVER</b> mode will terminate a <b>SURVEY IN</b> operation.</p> <p>Note that setting a Sensor to <b>ROVER</b> mode will terminate <b>FIXED BASE</b> Mode operation.</p> <p>Note that all Sensors can simultaneously be made <b>ROVERS</b> by writing to the J1939 Global Address (0xFF).</p>
GPS MODE	1 SURVEY IN MODE* (ECEF)	2 R/W	<p><b>Value 1:</b> Required Survey Accuracy 24-bit unsigned value</p> <p><b>Value 2:</b> Required Survey Duration 24-bit unsigned value</p>	<p>x10<sup>4</sup> m</p> <p>Seconds</p>	<p>Set this mode to initiate a <b>SURVEY IN</b> operation.</p> <p>2 Values are required: Desired Survey Accuracy and Survey Duration.</p> <p>During the <b>SURVEY IN</b> operation an additional <b>SURVEY IN STATUS</b> message is broadcast that reports the Current estimate of Accuracy and the Duration of the Survey In progress underway.</p> <p>Results are both ECEF and LLH coordinates that satisfy the required Accuracy and Duration.</p> <p>After the Survey completes successfully, the system will copy the ECEF and LLH coordinates into the GPS and automatically configure the Sensor for <b>FIXED BASE MODE (ECEF)</b>.</p> <p>Survey In results can be read using the <b>SURVEY IN RESULT</b> Request(s).</p> <p>The <b>SURVEY IN</b> mode operation ends when both the required Accuracy and Duration are met, or the mode is changed.</p>

Index	Sub Index	R/W	Values 1 & 2	Units	Comments
GPS MODE	1 SURVEY IN MODE* (LLH)	3 R/W	<b>Value 1:</b> Required Survey Accuracy 24-bit unsigned value  <b>Value 2:</b> Required Survey Duration 24-bit unsigned value	x10 <sup>4</sup> m  Seconds	Set this mode to initiate a <b>SURVEY IN</b> operation.  2 Values are required: Desired Survey Accuracy and Survey Duration.  During the SURVEY IN operation an additional <b>SURVEY IN STATUS</b> message is broadcast that reports the Current estimate of Accuracy and the Duration of the Survey In progress underway.  Results are both ECEF and LLH coordinates that satisfy the required Accuracy and Duration.  After the Survey completes successfully, the system will copy the ECEF and LLH coordinates into the GPS and automatically configure the Sensor for <b>FIXED BASE MODE (LLH)</b> .  Survey In results can be read using the <b>SURVEY IN RESULT</b> Request(s).  The <b>SURVEY IN</b> mode operation ends when both the required Accuracy and Duration are met, or the mode is changed.
GPS MODE	1 FIXED BASE MODE* (ECEF)	4 R/W	<b>Value 1:</b> Estimated Coordinate Accuracy 24-bit unsigned value <b>Value 2:</b> N/A	x10 <sup>4</sup> m	Set this Mode for Operation of this Sensor as a FIXED BASE using the ECEF GPS Coordinates for the Fixed Base location. Setting the Accuracy of the Coordinates is recommended. If unknown, try using 5 meters.  Note that a Sensor in <b>FIXED BASE</b> mode will not broadcast aiding messages unless its BASE address is identical to its DEVICE address. (See PGN 61184 (0xEF00) Configuration Commands.)
GPS MODE	1 FIXED BASE MODE* (LLH)	5 R/W	<b>Value 1:</b> Estimated Coordinate Accuracy 24-bit unsigned value <b>Value 2:</b> N/A	x10 <sup>4</sup> m	Set this Mode for Operation of this Sensor as a FIXED BASE using the LLH (Latitude, Longitude, Height) GPS Coordinates for the Fixed Base location. Setting the Accuracy of the Coordinates is recommended. If unknown, try using 5 meters.  Note that a Sensor in <b>FIXED BASE</b> mode will not broadcast aiding messages unless its BASE address is identical to its DEVICE address. (See PGN 61184 (0xEF00) Configuration Commands.)
<b>ECEF GPS Coordinates can be read using this request on successful completion of a SURVEY IN operation.</b>					
SURVEY RESULT	1 ECEF X	7 RO	GPS Coordinate	x10 <sup>4</sup> m	40-bit signed value
SURVEY RESULT	1 ECEF Y	8 RO	GPS Coordinate	x10 <sup>4</sup> m	40-bit signed value
SURVEY RESULT	1 ECEF Z	9 RO	GPS Coordinate	x10 <sup>4</sup> m	40-bit signed value
<b>LLH GPS Coordinates can be read using this request on successful completion of a SURVEY IN operation.</b>					
SURVEY RESULT	1 LATITUDE	10 RO	GPS Coordinate	x10 <sup>9</sup> Deg	Latitude in Degrees, positive is North. 40-bit signed value
SURVEY RESULT	1 LONGITUDE	11 RO	GPS Coordinate	x10 <sup>9</sup> Deg	Longitude in Degrees, positive is East. 40-bit signed value
SURVEY RESULT	1 HEIGHT	12 RO	GPS Coordinate	x10 <sup>4</sup> m	Height above WGS84 Ellipsoid 40-bit signed value

Index	Sub Index	R/W	Values 1 & 2	Units	Comments	
<b>GPS CONSTELLATION / UPDATE RATE</b>						
	1	GPS GLO GAL BDS	14	R/W	Value1 = 1	Constellations: GPS, GLONASS, GALILEO, BeiDou Update Rate: 8 Hz
	1	GPS GLO GAL	14	R/W	Value1 = 2	Constellations: GPS, GLONASS, GALILEO Update Rate: 10 Hz
	1	GPS GAL	14	R/W	Value1 = 3	Constellations: GPS, GALILEO Update Rate: 10 Hz
	1	GPS GLO	14	R/W	Value1 = 4	Constellations: GPS, GLONASS Update Rate: 10 Hz
<b>GPS Sensor Coordinates for Fixed Base Operation ECEF (Earth Centered Earth Fixed)</b>						
GPS Coordinate	2	ECEF X	0	R/W	GPS Coordinate	x10 <sup>4</sup> m Value1: 40-bit signed value
GPS Coordinate	3	ECEF Y	0	R/W	GPS Coordinate	x10 <sup>4</sup> m Value1: 40-bit signed value
GPS Coordinate	4	ECEF Z	0	R/W	GPS Coordinate	x10 <sup>4</sup> m Value1: 40-bit signed value
<b>GPS Sensor Coordinates for Fixed Base Operation LLH (Latitude, Longitude, Height)</b>						
GPS Coordinate	5	LATITUDE	0	R/W	GPS Coordinate	x10 <sup>9</sup> Deg Latitude in Degrees, positive is North. Value1: 40-bit signed value
GPS Coordinate	6	LONGITUDE	0	R/W	GPS Coordinate	x10 <sup>9</sup> Deg Longitude in Degrees, positive is East. Value1: 40-bit signed value
GPS Coordinate	7	HEIGHT	0	R/W	GPS Coordinate	x10 <sup>4</sup> m Height above WGS84 Ellipsoid Value1: 40-bit signed value

\* Note: A 'Read' of any of the GPS Modes (ROVER, SURVEY IN or FIXED BASE) will return the current Mode setting including the Values in use (For ROVER: '0' & '0', for SURVEY IN Desired Accuracy and Duration and for Fixed Base: Estimated Accuracy and '0').

## SYSTEM COMMISSIONING

Commissioning a system consists of:

- Setting **DEVICE** Addresses for each individual Sensor.
- Deciding and selecting the **CONSTELLATION/UPDATE RATE** for all Sensors.
- Deciding which Sensor will be the **BASE**, (the Reference and aiding source for all the ROVERS).
- Deciding on '**MOVING BASE**' mode versus '**FIXED BASE**' mode.
- If using '**FIXED BASE**' mode, setting or self-surveying the GPS coordinates of the fixed location BASE.
- Enabling the Base and Rovers.

### Setting **DEVICE** Addresses for each individual Sensor.

The Device Address for each individual sensor is set using the Sensor Configuration and Control message (PGN 61184). Each sensor when ordered and shipped as part of a kit will be delivered pre-addressed.

If multiple individual sensors are ordered, they will come from the factory with the same default Device Address.

If the Default Address does not match any address currently in use in the CAN bus network, one can simply plug in the new sensor and set its Device address as described in the section SENSOR CONFIGURATION AND CONTROL MESSAGE.

If there is an address conflict, (the new sensor has the same address as another on the network), temporarily remove the other sensor and set the Device address or set the Device address using a different network. (Note that if the sensor's address is not permanently assigned, it may negotiate for a new address on the network, in which case it would not need to be unplugged, only assigned a new address.)



Deciding and selecting the Constellation/Update Rate for all Sensors:

The system supports operating at one of 6 settings for GPS Constellation and Update Rate:

**GPS Constellations and Update Rates**

Constellations	ROVER Update Rate	MOVING BASE Update Rate	FIXED BASE Update Rate
GPS, GLONASS, GALILEO, BeiDou	8 Hz	8 Hz	1 Hz
GPS, GLONASS, GALILEO	10 Hz	10 Hz	1 Hz
GPS, GALILEO	10 Hz	10 Hz	1 Hz
GPS, GLONASS	10 Hz	10 Hz	1 Hz

All sensors can be set simultaneously (recommended) to the same Constellation and Update Rate by sending the GPS Configuration Request to the J1939 Global Address (0xFF).

Deciding which Sensor will be the BASE. (the Reference and aiding source for all the ROVERS):

One sensor will serve as the fixed location reference Base and aiding source for the moving Rovers.

Any Rover can be made a Base by setting its BASE address to be identical to its DEVICE address as described in the section SENSOR CONFIGURATION AND CONTROL MESSAGE. A BASE is either a 'MOVING BASE' if it is in ROVER mode, or a FIXED BASE if it is in FIXED BASE mode. FIXED BASE mode is recommended.

The Base address of all the Rovers and the Base can be set simultaneously by sending the Base Address Configuration Message to the J1939 Global Address (0xFF). See the section SENSOR CONFIGURATION AND CONTROL MESSAGE.

Deciding on 'MOVING BASE' mode versus 'FIXED BASE' mode:

By default, all sensors are shipped in Rover mode, with a Base address that is different from their Device address.

When the Base Address of a Rover is made identical to its Device address it becomes a 'MOVING BASE' and generates aiding messages at the same rate as specified by its Constellation/Rate setting. This mode does not have the same performance and accuracy as 'FIXED BASE' operation.

In FIXED BASE mode, the aiding messages are generated at 1 Hz, and the performance is better. FIXED BASE operation requires setting either LLH or ECEF GPS coordinates for the fixed, known location of the BASE. These coordinates can be set using the Sensor GPS Coordinates Request(s) for either LLH or ECEF.

If using 'FIXED BASE' mode, setting or self-surveying the position of the BASE:

Alternatively, the Base can be put into Auto SURVEY IN mode in which case the Base will self-survey its location. The ECEF or LLH results of the Self Survey can be read out for archival purposes.

At the end of a successful Auto Self Survey, the system automatically writes the ECEF and LLH coordinates into the GPS and changes the Mode to either FIXED BASE (ECEF) or FIXED BASE (LLH). (Which mode is chosen depends on which variation of the SURVEY IN Request was issued to start the SURVEY IN operation.

Enabling the Base and Rovers:

All the Rovers and the Base can be enabled by setting the Base address in all sensors simultaneously.

Commissioning Example:

**NOTES:**

- J1939 CAN Message ID's are constructed by specifying the Priority, the PGN, the Destination and the Source. 'PDU1' messages are Point to Point and require both Destination and Source Addresses. 'PDU2' messages are Broadcast messages and only require a Source Address.

- A J1939 CAN Message ID is: [(Priority<<26) + (PGN<<8) + (Destination<<8) + Source]. For a ‘PDU2’ Message, the ID is computed with Destination equal to ‘0’.
- All GPS Configuration messages are ‘PDU1’ Point to Point messages and require both Destination and Source Addresses, however, most of these messages support Broadcasting the ‘Global Address’ 0xFF. All sensors will Reply to a Broadcast message to 0xFF, easing configuration by permitting simultaneous configuration of multiple units, i.e. you can simultaneously configure the entire system.
- Some commands do not support the Global Address. Requests that cannot be made to the ‘Global Address’ will receive a J1939 ‘Access Denied’ Acknowledgement. (An example is the SURVEY IN Request.)
- In the examples below, CAN Message ID 0x1CEFFF00 breaks down as: Priority 6, PGN 61184 (0x00EF00), Destination ‘Global Address’ (0xFF) and Source ‘0x00’. PGN 61184 is a ‘PDU1’ message.
- Similarly, CAN Message ID 0x1EFC300 breaks down as: Priority 0, PGN 126720 (0x01EF00), Destination ‘Global Address’ (0xC3) and Source ‘0x00’. PGN 126720 is a ‘PDU1’ message.
- The following examples assume the device at address 0x00 is issuing commands and that 0xC3 is the chosen Base address.

The recommended method of commissioning the system is to:

1. Initially configure all sensors as ROVERS:
  - a. Set all Sensor’s Base address to an **unused** address (‘0xnn’), simultaneously:
    - i. (‘nn’ should be unused and between 0x01-0xFF)
    - ii. Example: 0x1CEFFF00 : E1 14 00 A1 nn 00 00 00  
 [0x1CEFFF00, FF is the Global Address, write to all sensors]  
 [0x1CEFFF00, 00 is the Source Address, ‘00’ in this example.]
  - b. Set all Sensors to Rover Mode, simultaneously:
    - i. Example: 0x1EFFF00 : 00 00 00 00 00 01 81  
 [0x81=Write, Index=1, Rover Mode = 0x01 ]
2. Select the Constellation/Rate for all sensors simultaneously:
  - a. Example: 0x1EFFF00 : 04 00 00 00 00 0E 81 (Select Const./Rate = 4, GPS/GLONASS @ 10 Hz)  
 [0x81=Write, Index=1, 0x0E is Constellation/Rate, 0x04 is GPS/GLONASS @ 10 Hz]
3. Either:
  - a. Perform an Auto SURVEY IN operation:
    - i. See the section AUTO SURVEY IN Operation)
  - b. Operate in MOVING BASE mode:
    - i. (Do nothing here, no other command necessary here. Not recommended due to lesser performance.)
  - c. Operate in FIXED BASE mode:
    - i. Set the LLH or ECEF GPS Coordinates in the sensor chosen to be the FIXED BASE:
      1. (This example assumes 0xC3 is the chosen Base Address.)
      2. 0x1EFC300 : 4E E7 3B 29 0A 00 00 85 (Latitude: 43.641464654 x10<sup>9</sup> Deg)
      3. 0x1EFC300: 44 42 4F 2D EF 00 00 86 (Longitude: -72.254275004 x10<sup>9</sup> Deg)
      4. 0x1EFC300: 08 79 14 00 00 00 00 87 (Height: 134.1704 x10<sup>4</sup> meters)  
 [0x1EFC300, C3 is the Base’s Address, 85/86/87 are Writes to Lat./Lon./Height]
    - ii. Put the Base into Fixed Base Mode:
      1. 0x1EFC300 : 50 C3 00 00 00 05 81  
 [0x1EFC300, C3 is the Base’s Address, 81 is a Write to GPS Mode, 05 is FIXED BASE LLH]  
 [“10 27 00” = 0x00C350 = 15 meters (5\*10000) = 0x002710, this is the 24 bit Accuracy estimate for the LLH coordinates entered.]
4. Set all Sensors’ Base address to the desired Base address, simultaneously:

- a. (This will program all Rovers to the same Base and activate the desired BASE, which will begin sending aiding messages.)
- b. Example: 0x1EFFF00: E1 14 00 A1 **C3** 00 00 00 (Assumes 0xC3 is the selected Base Address.)  
[0x1EFFF00, **FF** is the Global Address, A1 in 0x80 (Write) + size of 1 byte, write **C3** to the Base Address in all sensors]

**NOTE:** If the GPS coordinates are sent (written) to all Sensors, then in the event the Base fails, any other sensor could be 'promoted' to be a new replacement Base by simply changing its Device Address to match the Base Address, (one CAN command). It is necessary to move the replacement Base to the same fixed location described by the Base GPS Coordinates.

## ABSOLUTE MAXIMUM RATINGS

PARAMETER	NOTES	MIN		MAX	UNITS
Supply voltage		-30		36	VDC
Voltage on CANH, CANL with respect to GND		-3		15	VDC
CANH-CANL Differential		-6		+6	VDC

## ELECTRICAL CHARACTERISTICS

V+ = 5 to 36V, Analog Output  $R_L = \infty$ ,  $T_A = -40$  to  $+85^\circ\text{C}$ , unless otherwise specified.

PARAMETER	NOTES	MIN	TYP	MAX	UNITS
Supply voltage (V+)		5		36	VDC
Supply current	V+ = 12V V+ = 5 to 36V	70 20	75	80 165	mA
CAN bus rate		250		1000	Kbps, supports 250 Kbps and 1000 Kbps

## DYNAMIC PERFORMANCE

SPECIFICATION	NOTES	MIN	TYP	MAX	UNITS
RELPOS Output Data Rate				10	Hz
RELPOS Precision Horizontal Vertical	At TOV, $1\sigma$ , 10 sec		0.2 0.4		cm
RELPOS Accuracy Horizontal Vertical	At TOV, $1\sigma$ , 9 hours		0.7 1.8		cm
RELPOS Latency			90		mSec
Heading Accuracy	1-meter baseline, $1\sigma$		0.1		Degrees
Pitch and Roll Accuracy	$1\sigma$		0.1		Degrees

### CONNECTOR DIAGRAM

M12, Dual Male, 5-pin Connectors, (A-coded):

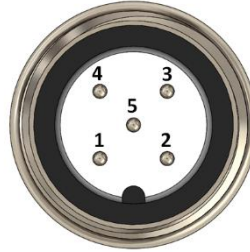

Male End External View

### PIN DESCRIPTIONS

PIN	NAME	DESCRIPTION
1	Shield	Shield (Case)
2	V+	Supply Voltage
3	GND	Ground (Power Return)
4	CAN H	CAN Bus High
5	CAN L	CAN Bus Low

Note: The connector has an Industry Standard M12 CAN Bus Pinout and is compliant with industry standard DeviceNet™ or CANopen network cabling standards and products.

### CAN TERMINATION:

This device contains an Internal CAN Terminator that is not activated in the default configuration.

A properly terminated CAN bus network has a pair of 120 Ohm terminators at the two points furthest from each other on the CAN network.

In typical CAN networks either none of the devices have internal CAN Termination enabled (external dedicated CAN terminators are used) or at most 2 device(s) have internal CAN terminator(s) enabled.

Typical CAN network installations have separate terminators designed into the network to simply debugging and improve reliability since the removal or failure of a device containing an internal CAN terminator will usually cause the network to fail to function properly and be difficult to debug until a CAN terminator is installed (to replace the one lost in the failed device).

### SENSOR WIRE HARNESS SHIELDING & WIRING REQUIREMENTS

SignalQuest has tested and recommends one of the following three options for use with the sensors. The three options are listed in order of recommendation.

1. Two Shielded Twisted pairs with Drain wire, 5 wires total (1 pair for power, 1 pair for CANH/CANL, 1 Shield/Drain wire)
  - a. DeviceNet, CANopen compatible wiring, or SAE J1939/11 wiring with the addition of a shielded twisted pair for power, with shield connected to case ground via grounding lug on case.
2. Two Unshielded Twisted pairs, 4 wires total, (1 pair for power, 1 pair for CANH/CANL)
  - a. SAE J1939/15 compliant wiring with the addition of a twisted pair for power.

3. Four Wire Spiral Wound, 22 AWG, 1 to 3 twists per foot. This option is not supported by the J1939 specifications but is widely used by industry.

Shielded twisted pair (Option 1 above) provides the best performance. Options 2 and 3 are sufficient for certain cost-conscious applications where shielded wiring is not desirable.

In order to meet certain high field immunity requirements beyond the specifications listed above, the following installation requirements must be observed:

1. The SHIELD signal (if used) must have a direct connection to GND at some point in the wiring harness and this point should be as close as possible to the power supply (or battery) negative terminal.
2. Shielded cabling for all communications/power signals between the sensor and the CAN bus controller is required.
3. It is also required to strap the sensor's enclosure to a chassis ground via the 0.25" deep 6-32 screw hole available on the surface of the sensor. Use of a screw, washer, lock washer and braided copper mesh to attach the enclosure to a bare metal tapped hole in the vehicle's metal floor is recommended. Conductive epoxy may be useful to prevent the screws from corroding or coming loose over time.
4. Many customers have met EMI/RFI requirements without Shielded cable (2 above) or grounding at the sensor (3 above). Likewise, requirements have been met using Wiring Option 2 (2 unshielded twisted pairs per SAE J1939/15). The customer is responsible for testing to prove this.

## MEASUREMENT DEFINITIONS

**Measurement Axis** is a vector pointing from the side of the device where the connectors are to the side opposite the connectors.

**Body X Axis** is the same as the *Measurement Axis*.

**Body Y Axis** is a vector perpendicular to the *Measurement Axis*, extending to the right when viewed from the connector side of the device, with the GPS Antenna oriented upward.

**Body Z Axis** is a vector perpendicular to the X and Y Axes, pointing opposite the direction of the Antenna.

**IMU Measurements** (Acceleration and Angular Rate) are given for the three *Body Axes*, X, Y and Z.

**Gravity** is a vector pointing from the device to the center of the Earth.

**Horizontal** is a plane that is perpendicular to *Gravity*.

**Elevation** is the angle between the *Measurement Axis* and a plane that is *horizontal*. *Elevation* is 0° when the *Measurement Axis* is in a plane that is *horizontal*. *Elevation* increases when the *Measurement Axis* is tilted up, away from the surface of the Earth.

**Roll** is right-handed rotation about the *Measurement Axis*. *Roll* is 0° when the *Body Y Axis* is *horizontal*, and the GPS Antenna is within 90° of *gravity* and pointing away from the surface of the Earth. Right-handed rotation means that *Roll* increases when the sensor is rotated clockwise about the *Measurement Axis*, when the *Measurement Axis* is pointing away from the viewer.

**Gimbal Lock** occurs when *Elevation* is at ±90° (also meaning that the *Measurement Axis* is parallel to gravity, pointing up or down). When the device is near the Gimbal Lock position, *Roll* cannot be measured. The *Roll* measurement may be stable, or it may drift about at random, but it cannot be relied upon in Gimbal Lock.

**Relative Position** applies when one sensor is aided by another sensor acting as a Base. The *Relative Position* describes the offset, North, East and Down from the Base to this sensor.

**Relative Base Line** applies when one sensor is aided by another sensor acting as a Base. This is the physical distance between the Base and this sensor.

**Relative Heading** applies when one sensor is aided by another sensor acting as a Base. This is the direction of the vector between the Base and this sensor, projected onto a plane that is horizontal. It ranges from 0° to 360°, with 0° being North.

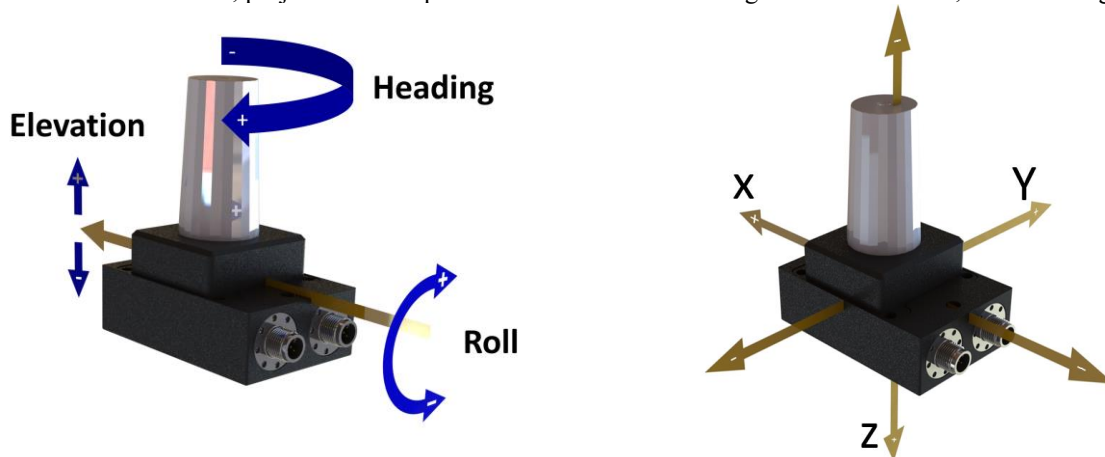

## PACKAGE DIMENSIONS

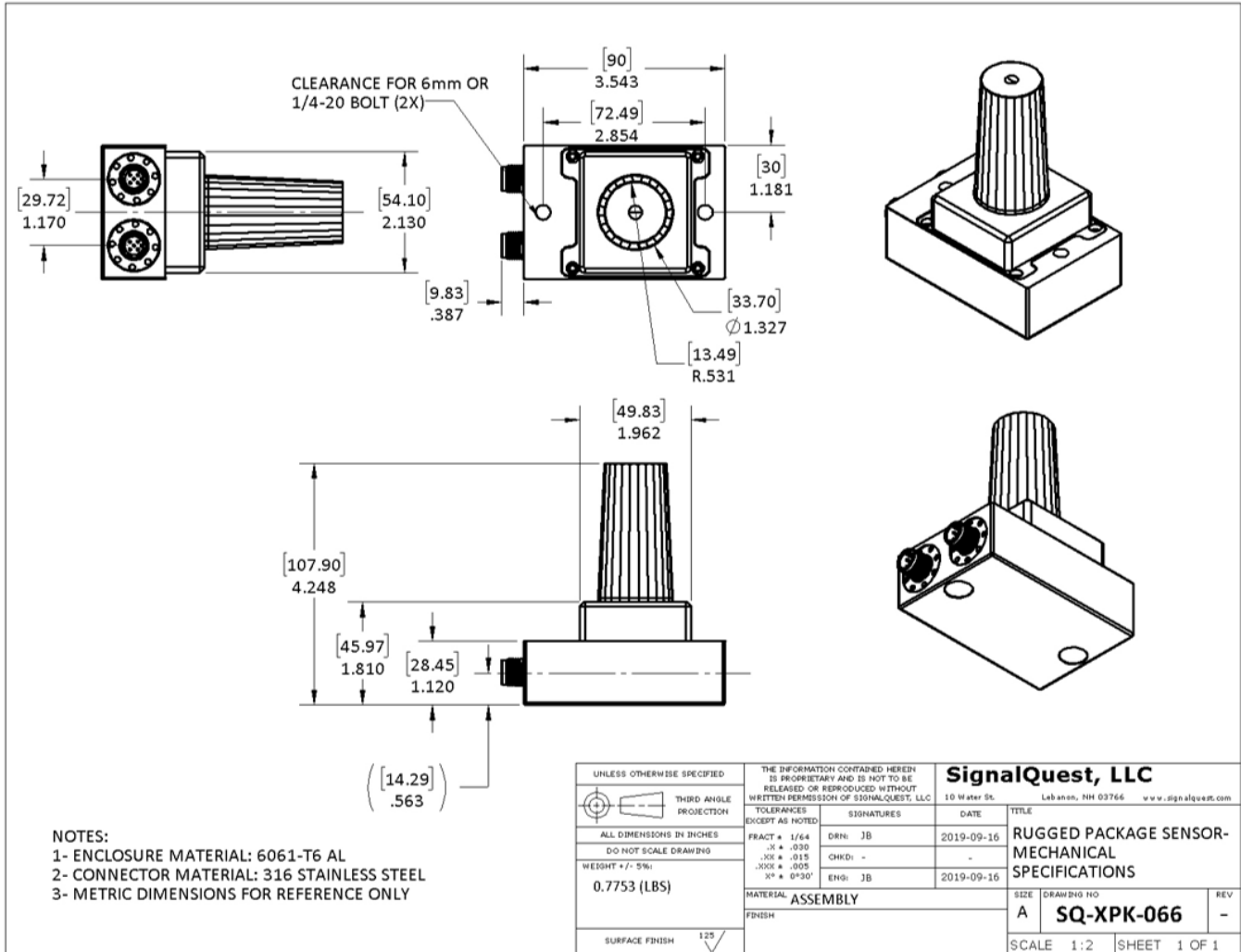

## LIMITATIONS AND WARNINGS

### TESTING

The performance of each system is verified through build-time testing. Each system is tested before and after factory calibration to ensure reliable performance.

### SYSTEM INTEGRATION TESTING

Thorough testing should be carried out prior to product release to ensure system integration has not introduced unforeseen problems. The system integrator assumes the ultimate responsibility for the safety of the target application.

### NOTICE

Information furnished by SignalQuest, Inc is believed to be accurate and reliable. However, this document may contain ERRORS and OMISSIONS. Accordingly, the design engineer should use this document as a reference rather than a strict design guideline and should perform thorough testing of any product that incorporates this or any other SignalQuest product. No responsibility is assumed by SignalQuest, LLC for the use of this information, or for any infringements of patents or other rights of third parties that may result from its use. Specifications are subject to change without notice. No license is granted by implication or otherwise under any patent or patent rights of SignalQuest, LLC. Trademarks and registered trademarks are the property of their respective companies.

## REVISION TABLE SQ-NPG-0021

Rev. #	Rev. Date	Revised By:	Description	Lot Numbers
A	2019-09-12	JLM/ PBT	Initial Release – PRELIMINARY	
B	2019-09-19	JLM/ PBT	All relative measurements are now signed 32-bit integers.	
C		JLM	Satellites and various corrections	
D	2019-10-12	JLM	GPS Request/Reply Configuration and various corrections	
D.01	2019-10-16	JLM	Minor Formatting to SURVEY IN Status Message	
E	2019-10-30	JLM	Clarifications regarding Satellite numbering, configuration commands, and more details.	
E.01	2019-10-30	JLM	More clarifications, minor corrections.	
E.02	2019-11-10	WBK	Marketing updates	
F	2019-11-11	JLM	Addition and documentation of Auto Survey In feature	
F.01	2019-11-15	JLM	Minor improvements for clarity and accuracy.	